

Specification Summary – ET2-32

- 6 Star WELS
- Watermark
- Robust construction highly suitable for Commercial use
- Basin mounted
- Cost effective popular option for Education, Hospitals & Industrial sectors as well as all public bathrooms
- Hygienic no touch operation
- No fixed run time for maximum water saving
- Confirmation time of 1-2 seconds
- Auto off after 1 minute if sensor obstructed
- Self-adjusting forward-facing sensor
- Normally suitable for use with stainless steel sinks/troughs
- Battery only or mains power with battery back-up
- Water pressure range between 100-500kPa
- Water Inlet – 15mm ½" G
- Single water feed – pre-mix water (Mixing valve available to order if required, see ET-HCV)
- Water temperature - 1-50°
- Flexi hose - approx. 60cm long
- Sensor control cable from base of spout - approx. 1M long
- Transformer cable (if used) approx. 1M

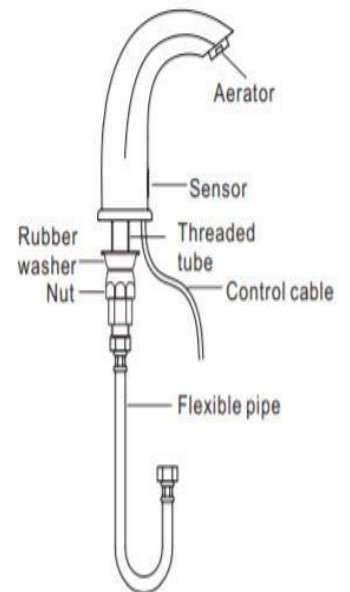

CONTROL BOX

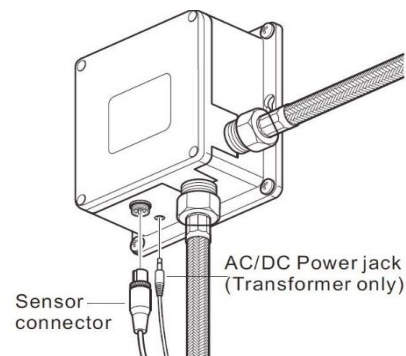
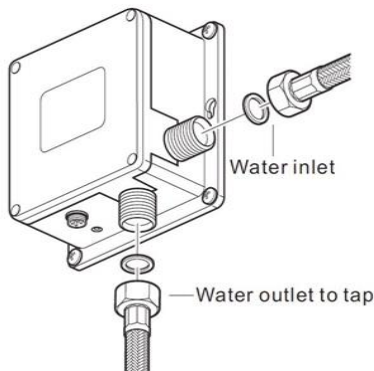

Hands Free Hygiene

P: 1800 782 088 | sales@handsfreehygiene.com.au

Handsfreehygiene.com.au